

Forgive us the wrongs we have done

Theme: Forgiveness!!

Games:

Tunnel ball: Choose two teams (or more). They stand in a line and pass the ball through their legs, then the person at the back runs to the front of the line and repeats the process. The winner is the first team, to have the person who started back at the front. Variations of this game can be side to side or over/under etc. If the teams are uneven you could go against the clock or just let someone go more than once.

Reactions: Normally used with soft balls between pairs but you could use anything like a pencil or any object you think may be appropriate. Each pair stands facing each other with the object on the floor in between them. The leader will call out a body part like 'head' and the children have to touch the head of their partners using their hands and not the object. You could be looking out for the fastest pair. The leader then calls out another body part (e.g. shoulders) and the children do the same with the shoulders. When you shout 'ball' the children would have to grab the ball as quick as they can, or whatever item there is available to use instead of a ball and try to beat their opponent!

Memory Verse: *"Forgive us the wrongs we have done as we forgive the wrongs that others have done to us". Matthew 6 v 12* You could use this as "Chinese Whispers"

Introduction: Ask the children if they had £5 but one of the friends took half of their money without asking how would they react?

Story: *Matthew chapter 18 verse 21-35.* The parable of the unforgiving servant.

Application: We know that everyone has done something wrong in their lives. It is not a nice feeling we have when we do wrong things, especially if what you have done has hurt or upset someone close to you. Forgiving someone is a great way of showing Gods love. Being forgiven is also important because it can take all the guilty feelings away that can make us feel sad and upset. We should always try our best to forgive people and ask God to help us. We should ask God to forgive us. Jesus tells us that if we forgive others, we will be forgiven!

Craft: Cut out and decorate a cross to remember that our sins were forgiven when Jesus died on the cross. See resources section for outlines.

Prayer: *"Father, we thank you that are an amazing forgiving God! Thank you that you're so kind and generous to us. Help us to forgive others as you forgive us."*

Resources: There is a funsheet for the children to do.

Song: Cliff Richard's *Millennium prayer*. You could use this song if you have a copy as a quiet reflective song and maybe get the children to sing it towards the end of the song.

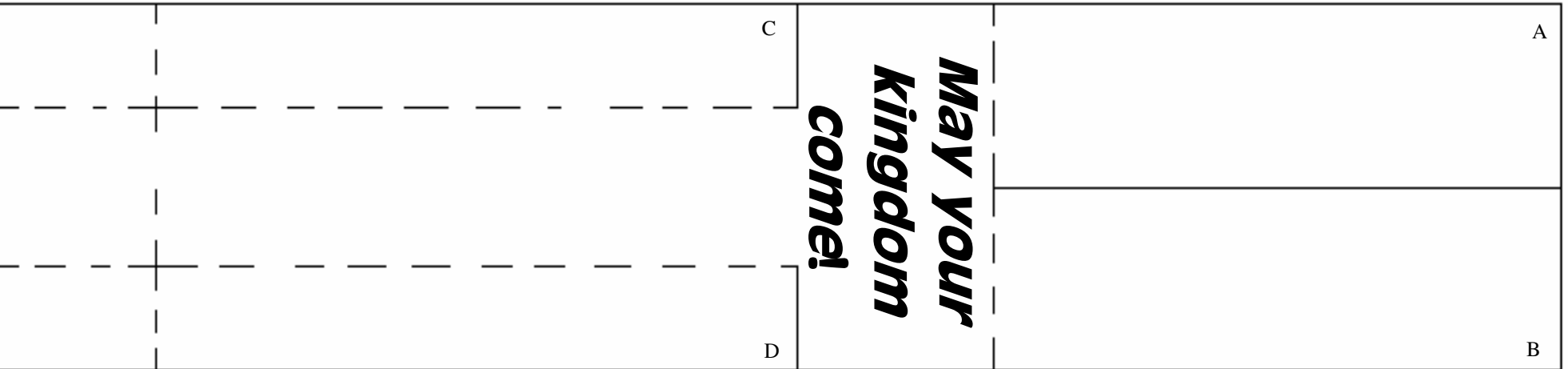
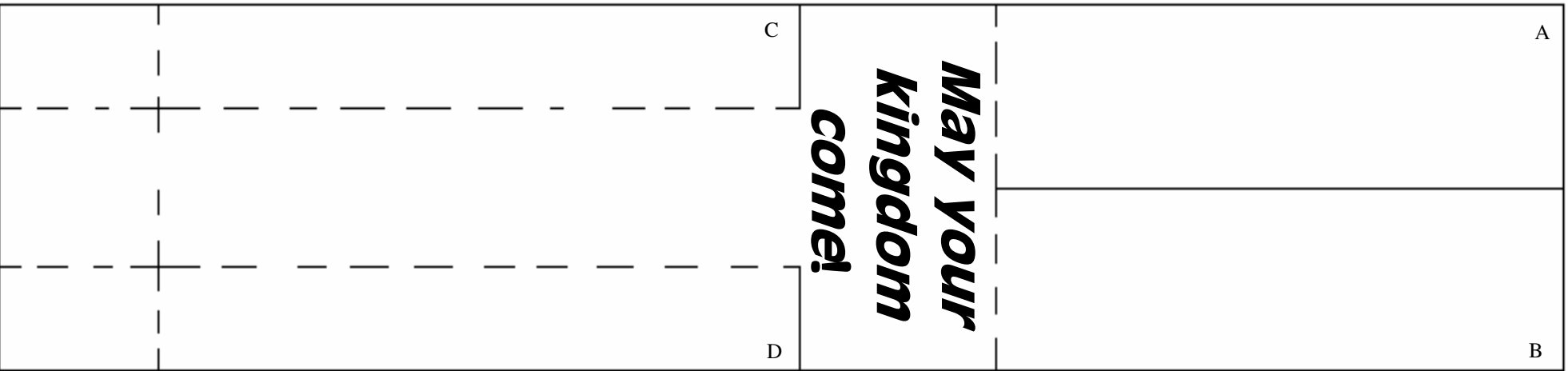

- **Cut along all the solid lines on the diagram to the right.**
- **Fold flap A forward and flap B back.**
- **Fold flaps C and D both forward along the dotted lines.**
- **Fold along the line E upward to give a weight at the bottom.**
- **You just drop the model with the blades facing upwards and weight at the bottom for the best results.**

- **Your completed helicopter should look like this!**

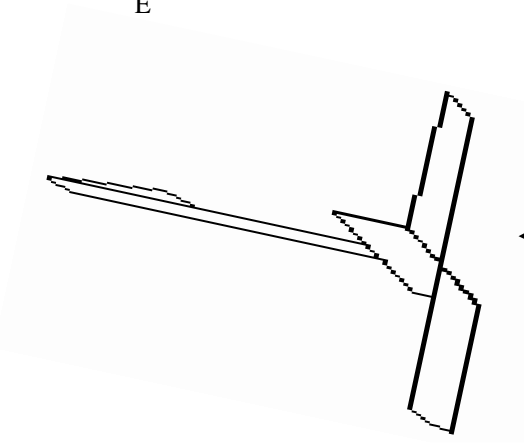

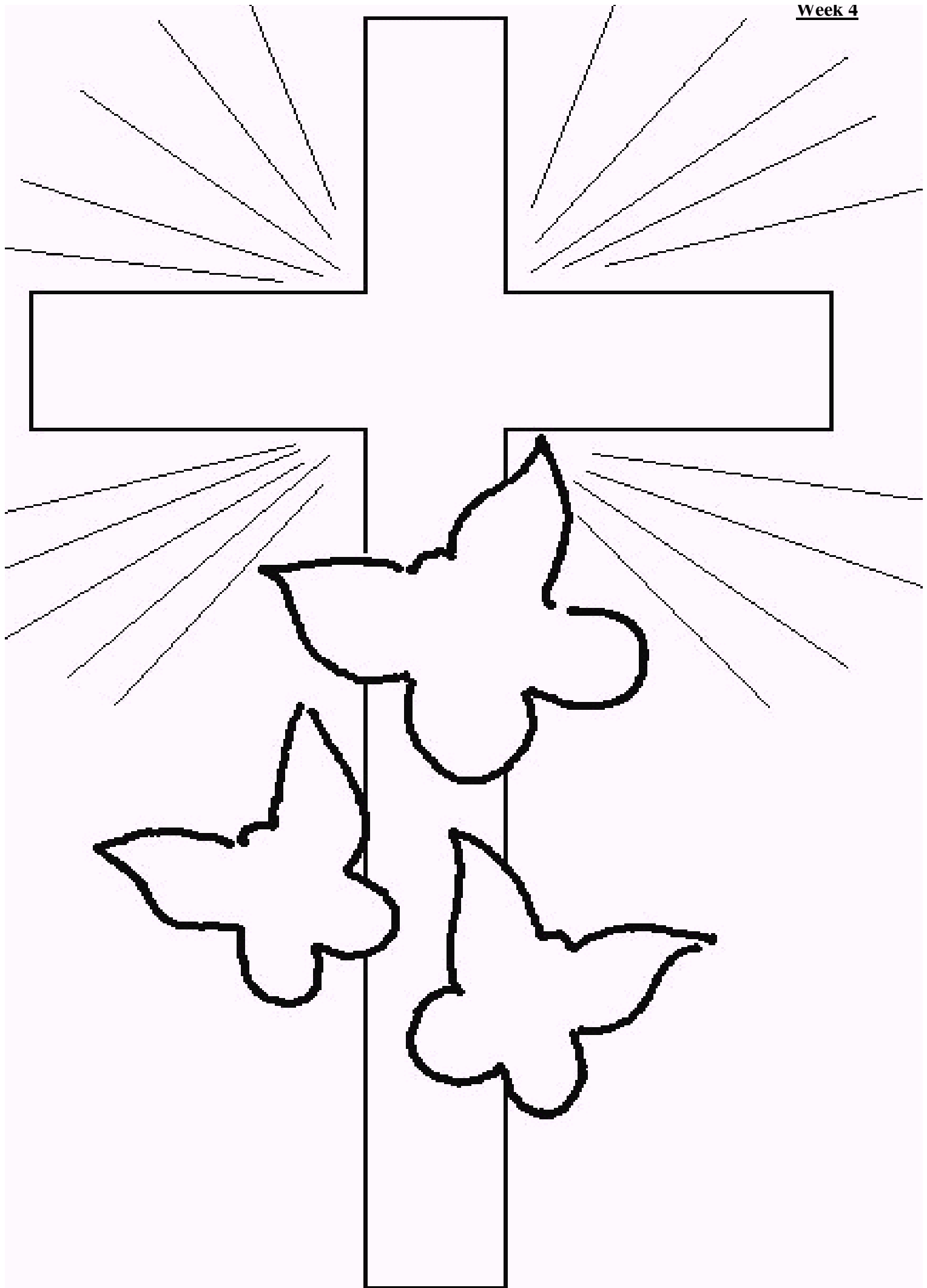



1 Which one says sorry? 2

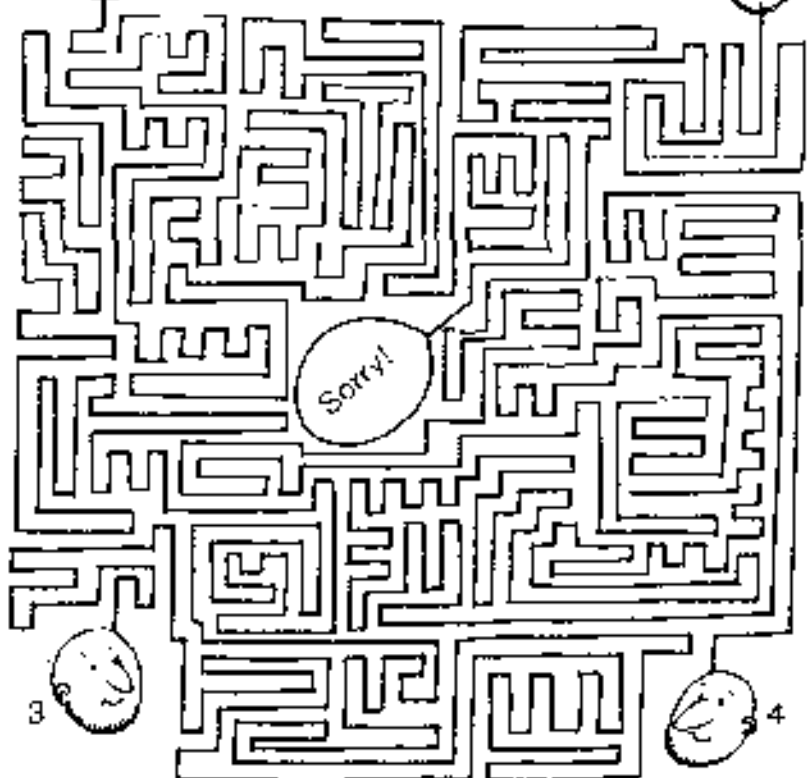

M	I	L	L	O	S	N	S	C	F
I	S	A	P	C	H	I	L	O	D
A	S	N	E	O	D	E	R	E	C
J	N	E	U	E	U	G	B	N	H
A	O	G	R	O	A	N	G	R	I
L	I	G	R	V	P	O	D	G	L
I	L	N	E	Y	A	E	K	S	D
S	L	I	A	J	B	N	F	O	R
E	I	K	V	T	K	I	T	G	E
F	M	S	E	V	E	N	T	Y	N

- ANGRY
- CHILDREN
- DEBT
- FORGAVE
- JAIL
- KING
- MILLIONS
- POUNDS
- SERVANT
- SEVENTY

Forgive us the wrongs we have done as we forgive the wrongs that others have done to us. Matthew 6 v 12

Make 10 or more words out of the word FORGIVENESS